

**MAIN ARMORED TANK DEPARTMENT
OF THE MINISTRY
OF DEFENSE
OF THE RUSSIAN FEDERATION**



**METHODOLOGICAL
RECOMMENDATIONS FOR
ENSURING THE PROTECTION OF
ARMOURED PERSONNEL
FROM FPV DRONES (BASIC PROVISIONS)**

Moscow 2023

CONTENT

p.

1. General Provisions.....	3
2. Main tactical and technical characteristics of FPV "drones" used by the Ukrainian Armed Forces.....	4
3. Equipping the APC with a protective visor and protective nets.....	6
3.1 Equipping the BTR-82A with a protective visor and protective nets.....	6
3.2 Materials and tools required for manufacturing of a protective visor and protective nets.....	3.3 7
Recommendations for installing a protective visor and protective nets on the BTR-82A.....	7
4. Equipping the armored personnel carrier with electronic countermeasures.....	10
4.1 Installation of the LGSh-689 noise generator on the BTR-82A...	10
4.2 Recommendations for installing the LGSh-689 noise generator on the BTR-82A.....	11
4.3 Installation of the Volnarez unmanned aerial vehicle suppression system.....	12
4.4 Recommendations for installation of the Volnarez complex....	12
4.5 Safety requirements for the operation of electronic countermeasures.....	14

1. General Provisions

An unmanned aerial vehicle is an aircraft that does not have a pilot (crew) on board, uses engine thrust and aerodynamic forces to fly in the atmosphere, has a target load that determines its purpose, and carries out a flight both according to a predetermined program and using remote control.

During combat operations, the Ukrainian Armed Forces widely use FPV drones (unmanned aerial vehicles), including retrofitted commercial models, to destroy armored vehicles and military equipment.

Small size, high accuracy and the use of a wide range of weapons make FPV "drones" are an effective means of destroying armored and military equipment.

The main types of FPV "drones": 1.

"Drones"-bombers of the "quadcopter" type are designed to destroy models of armored vehicles and military equipment by dropping fragmentation ammunition (hand grenades of the RGD-5 type, F-1, VOG-17 fragmentation grenade shots) and cumulative ammunition (RKG-3, PTAB Mk118 and BLU-77 (USA), PTAB KV-44 DM1244 (Germany), KOBE M42/M46 and M77 (USA)) due to hitting the roof, open hatches or hitting the target area. Drone bombers are most effective against stationary objects.

2. Kamikaze drones of the aircraft or quadcopter type, equipped with a built-in cumulative or high-explosive fragmentation warhead (RPG warhead PG-7L, PG-7M, PG-9S, PG-18) and designed to destroy armored vehicles and military equipment by hitting (ramming) the upper hemisphere of the target.

Methods of combat use of FPV drones: 1. Striking areas of deployment, positions of units of the Russian Armed Forces, places of accumulation of equipment with known coordinates.

2. "Free hunting" in rear areas, on supply and evacuation routes.

2. Main tactical and technical characteristics of FPV

"drones" used by the Ukrainian Armed Forces

Name characteristics	Meaning of the characteristic			
	«Hawk»	"Cross"	R-18 "May"	wick 3"
Type	Kamikaze drone		"drone"- bomber	
	aircraft type	quadcopter	quadcopter	
Country of origin	Ukraine			PRC
Types of weapons used	Warheads of hand-held anti-tank weapons grenade launchers PG-7L, PG-7M, PG-9S, PG-18		VOG-17, RGD-5, F-1, RKG-1600x3, RKG-3, PTAB Mk118 and BLU-77 (USA), PTAB KV-44 DM1244 (Germany), KOBÉ M42/M46 and M77 (USA)	
Mass, kg: payload maximum takeoff	0,4 5,5	2 6	4 11	0,1 10
Maximum flight duration, l	150	20	15	48
Maximum range flight, km	55	4,5	5	15
Maximum flight speed, km/h	120	60	100	69
Geometric dimensions, m: width length	2,1 1,45	0,35 0,4	 1,1	0,93 1,14

Basic methods of protection against FPV "drones"

1. Equipping the APC with additional turret roof protection modules (protective canopies) and protective nets.
2. Equipping the armored personnel carrier with electronic suppression systems for control and navigation channels, and electronic FPV "drone" systems.

Appearance of the main FPV "drones"



«Hawk»



"Cross"



«R18»



"Maywick"



ST-35 "Silent Thunder"



UJ-31 "DOWNPOUR"

3. Equipping the APC with a protective visor and protective nets

3.1 Equipping the BTR-82A with a protective visor and protective nets



Protective visor

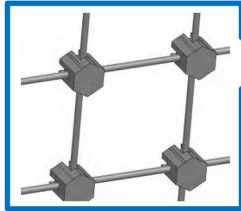

Protective net

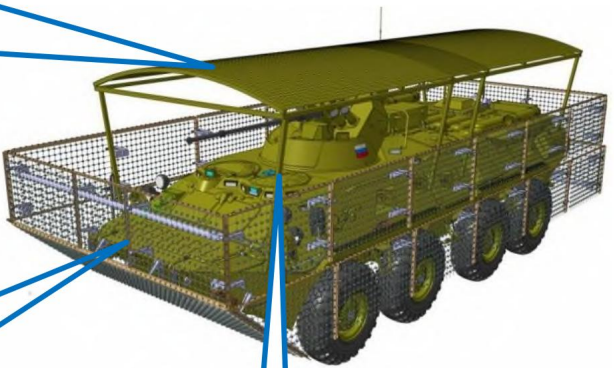

Metal support

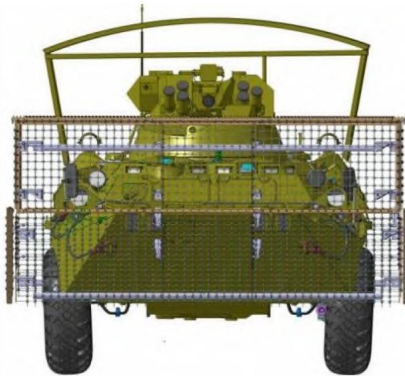

External view of the BTR-82A with a protective visor and protective nets

3.2 Materials and tools required for making a protective visor and protective nets

1. Mesh screen (cell size 20 x 20 mm or 30 x 30 mm), made of steel rod (diameter 2 - 3 mm) - 16 m².
2. Frame of the protective canopy: - profile with a section of 30x30 mm (pipe with a diameter of 30 mm) - 75 running meters.
3. Support: - profile with a section of 40x40 mm (pipe with a diameter of 40 mm) - 8 running meters.
4. Camouflage net - 36 m of cord with a diameter of 3-5 mm.
5. Bolt M12x40 - 2 or aramid (textile) 850 pcs.
6. Nut M12 - 850 pcs.
7. Welding machine - 1 pc.
8. Angle grinder - 1 pc.
9. Electrodes 3 mm - 3 kg.
10. Cutting disc - 10 pcs.

3.3 Recommendations for installing a protective visor and protective nets on the BTR-82A

First, the frame of the protective canopy is made from metal pipes of square cross-section 30x30 mm of the required length, followed by welding them together. Then, a roof made of

mesh screen with a cell size of 20 x 20 mm (30 x 30 mm).

To roll off fallen ammunition, the roof of the canopy must be made with inclined surfaces of **15-25 degrees** from the horizontal.

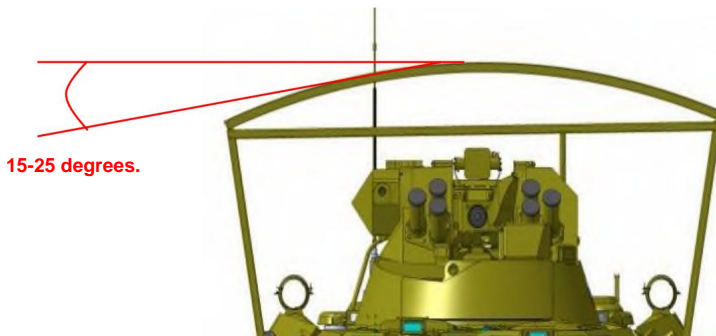

The manufactured protective visor is installed on the APC body **on 6-8 steel supports** (a profile with a cross-section of at **least 40x40 mm** or a pipe with a diameter of **at least 40 mm**).

The installation height **is not less than 500 mm** from the roof of the armored personnel carrier turret.

not less than 500 mm

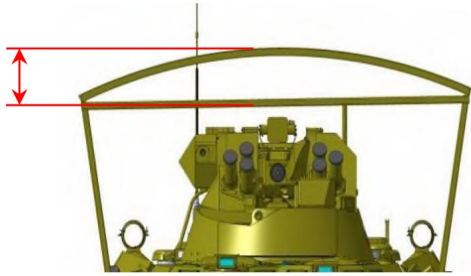

Steel supports for attaching the canopy **are mounted** to the structural elements of the APC hull, **taking into account the possibility of opening (closing) hatches**, as well as maintaining the functioning of external equipment and the possibility of firing weapons.

Manufacturing protective nets Nets are

manufactured according to the dimensions of the protected element (projection). For manufacturing

the net, it is best to use aramid or textile cord with a diameter of 3-5 mm.

Weave a net from the cord with a cell **size of at least 75 x 75 mm, but not more than 80 x 80 mm**. If available, you can use a ready-made net. A bolt with an M12 nut is fixed in the cell nodes.

The cell size is not less than 75 x 75 mm, but not more than 80 x 80 mm

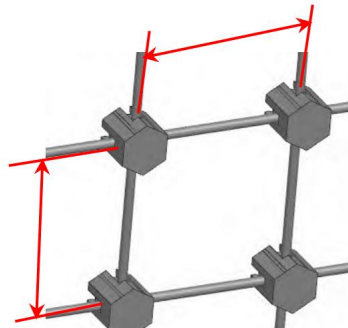

The nets are fixed on frames. Frames for installing the nets are made according to the dimensions of the protected element of the armored personnel carrier (windshields, doors, hatches) from metal pipes of square section 30x30 mm of the required length with subsequent welding them together.

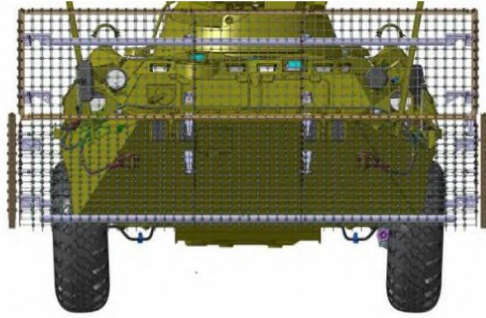

Frame by the size of the frontal projection of the armored personnel carrier

Frames with nets are installed on brackets at a distance of **at least 200 mm** from the body.

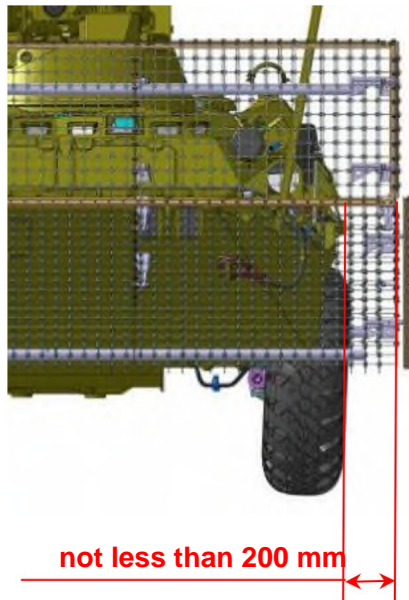

The nets are attached taking into account the possibility of **opening (closing) hatch covers, turning the turret**, as well as the operation of external equipment (sights, weapons, etc.).

4. Equipping the armored personnel carrier with electronic warfare equipment suppression

4.1 Installation of the LGSh-689 noise generator on the BTR-82A

Main performance characteristics of the noise generator LGSh-689

Parameter	Parameter value
Suppression range "drones", m	200
Range LGSh-689, MHz Operating mode	860-886 / 902-928
Directional pattern	continuous
Zones	omnidirectional
generator radiation maximum	towards the front and back parts of the VAT sample
Operating voltage, V Battery	24
life, h Power consumption, W	2
Impact on equipment	70
radio communications	absent
Installation method	magnetic mount on metal base, under at an angle of 45° to the horizon perpendicular to the longitudinal axis sample
Operating temperature	From -10 to + 40 °C

Composition of the generator LGSh-689

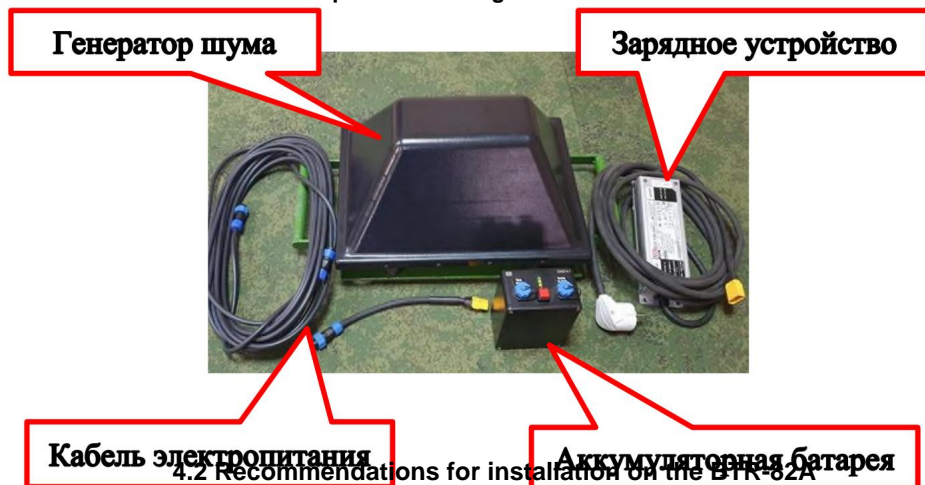

4.2 Recommendations for installation on the BTR-82A noise generator LGSh-689

1. **Mount the antenna** modules on the sample

on a flat metal surface over the entire area

grounds.

2. To ensure protection of connecting cables from small arms bullets and fragments of artillery ammunition, as well as to protect against mechanical impacts during operation, **the power supply cable should be placed on the sample in technological niches and recesses** and secured to the structural elements of the sample with plastic ties.

Operating restrictions LGSb-689 1. The product should not be exposed to direct sunlight and precipitation.

2. It is prohibited to place the antenna near metal enclosing structures, as well as to cover the antenna of the product. 3. It is prohibited to place foreign objects and obstacles at a distance of at least 1 m from the product.

IMPORTANT! When installed on a sample **together with the antenna** visor, the LGSb-689 noise generators **must not be covered by the metal elements of the sample.**

Устанавливай антенные модули на ровную металлическую поверхность (например: на крышу козырька)

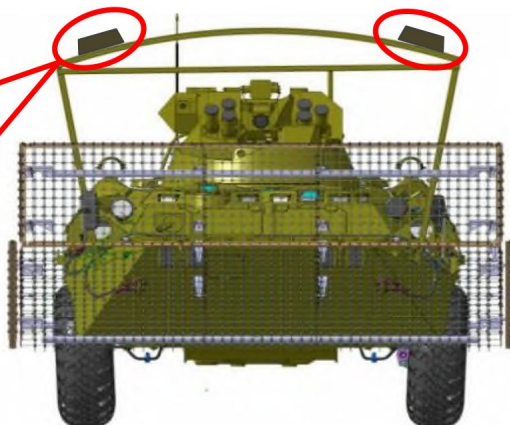

Recommended installation location

of LGSb-689 noise generators on the BTR-82A
4.3 Installation of the Volnoez unmanned aerial vehicle suppression system

Main performance characteristics of the Volnorez suppression system

Parameter	Parameter value
Range of suppression of "drones" (on a stationary/moving object), m	120/50
Frequency range, MHz	300-530 / 800-930 / 2300-2600 5700-5945
Operating mode	constant
Directional pattern Operating voltage,	spherical
V Power consumption, W	12/24
Impact on radio communication equipment	300 absent
Installation method	magnetic mount
Operating temperature	From -40 to + 60 °C

4.4 Recommendations for installation of the "Volnorez" complex

1. **Mount the antenna modules** on the sample **on a flat metal surface** over the entire area of the base of the antenna modules.
2. To ensure protection of connecting cables from small arms bullets and fragments of artillery ammunition, as well as to protect from mechanical impacts during operation, **connecting cables should be placed on the sample in technological niches and recesses** and secured to the structural elements of the sample with plastic ties.
3. During installation and operation of the complex, **do not** expose **allowed on** excessive mechanical **antenna modules (stepping on them with your feet, using a hammer (sledgehammer)** and other metalworking tools).

IMPORTANT! When installed on a sample **together** with the canopy, **the antennas of the Volnorez complex must not be covered by the metal elements of the sample.**

Installation of elements of the "Volnorez" complex

Антенный модуль
крепи на ровное
металлическое
основание путем
примагничивания



Antenna module

Перед монтажом
соединительных
кабелей к блоку
ОТКЛЮЧИ
ЭЛЕКТРОПИТАНИЕ



Switching block

Пульт управления
крепи на ровное
металлическое
основание путем
примагничивания



Remote control

ВНИМАНИЕ! Подключение комплекса «Волнорез»
к бортовой сети образца осуществляй через предохранитель
или автомат защиты

Устанавливай антенные модули на ровную
металлическую поверхность
(например: на крышу козырька)

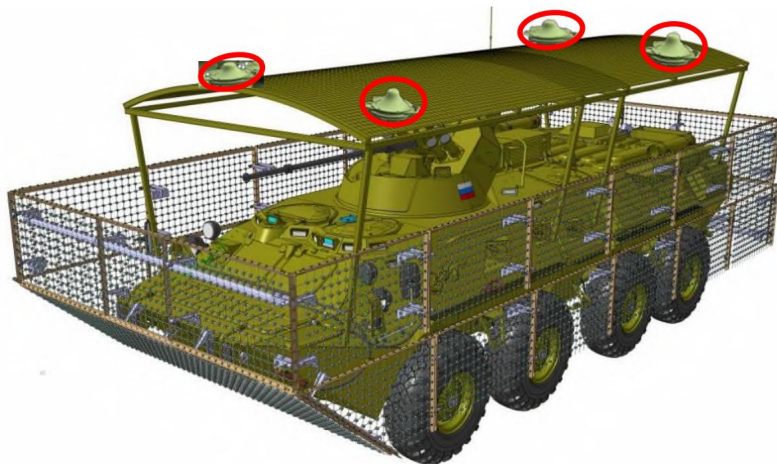

Recommended installation location of the
Volnoretz complex on the BTR-82A

4.5 Safety requirements for the operation of electronic countermeasures

IT IS PROHIBITED:

1. Transport personnel on top of the sample body with the systems turned on. 2. Conduct repair work and maintenance with the systems turned on. 3. Mount (dismount) antenna modules.

with the power supply on. 4. Before performing welding work on the sample, disconnect the UAV countermeasure systems from the power supply.